



العين RACEWAY

UAE ROTAX MAX CHALLENGE 2015-16



Organised by **AL AIN RACEWAY KART CLUB**

In Association With



SERIES TECHNICAL REGULATIONS VERSION 30.09.15

REGULATIONS

The final text of these Technical Regulations shall be the English version, which will be used, should any dispute arise as to their interpretation. Headings in this document are for ease of reference only and do not form part of the regulations.

1 – GENERAL

1.1 – CATEGORIES

Karts used in the UAE RMC Championship are divided into the following groups:

- ROTAX 125 Micro MAX * (cylinder capacity 125 cc)
- ROTAX 125 Mini MAX * (cylinder capacity 125 cc)
- ROTAX 125 Junior MAX (cylinder capacity 125 cc)
- ROTAX 125 MAX (cylinder capacity 125 cc)
- ROTAX 125 MAX DD2/MASTERS (cylinder capacity 125 cc, 2-speed)

* For ROTAX 125 Mini MAX and 125 Micro MAX please also see Appendix

1.2 – AMOUNT OF EQUIPMENT

For each race event (from non-qualifying practice to the Final), the maximum amount of equipment is:

- 1 chassis
- 1 sets of dry tyres (total 2 front tyres plus 2 rear tyres)
- 2 engines

2 – EQUIPMENT

2.1 – CHASSIS

For UAE RMC Championship any CIK homologated chassis (according to Article 2.3 of the CIK Technical Regulations) is allowed, subject to specific class criteria below.

Please note that chassis' produced by Intrepid Driver Program are NOT permitted for use, with the exceptions of 'Rocket DD2' chassis numbers 0028-0032 and 'Sirius' chassis number 0045.



✉ P.O.Box 85393. Al Ain. UAE.

☎ +971 (0) 3 768 6662

📠 +971 (0) 3 768 8477

@ sales@alainraceway.com

🌐 www.alainraceway.com

125 Micro MAX

Wheel base: min 850mm, max 950mm (± 5 mm)
 Diameter of main tubes 28mm, round tubing only
 Maximum overall width 1200mm
 Eccentrics for the stub axles are allowed
 No front wheel hubs permitted
 Rear axle: 25mm solid or 30mm hollow, minimum wall thickness according to CIK
 Brake system must work on rear wheels only and have a valid CIK-FIA homologation
 Front rims with tyres mounted: maximum 135mm, minimum 125mm
 Rear rims with tyres mounted: maximum 150mm, minimum 140mm

125 Mini MAX, 125 Junior MAX and 125 MAX classes

Maximum diameter of chassis tubing = 32 mm, round tubing only
 Maximum diameter of rear axle = 50 mm, minimum wall thickness according to CIK
 Maximum overall width 1400mm
 Any Brake system must work on rear wheels only and have a valid CIK-FIA homologation
 Front brakes are not allowed in the 125 MAX Junior MAX class
 Front brakes are allowed in 125 MAX class. **Please note that front brakes will not be permitted from the 2015-16 season onwards.**

125 MAX DD2 and DD2 Master classes

Only Rotax-approved chassis are permitted (<http://www.rotax-kart.com/Max-Challenge/MAX-Challenge/Approved-Chassis-125-MAX-DD2>).

Chassis must be designed according to CIK-FIA rules for shifter classes (front and rear brakes mandatory). Any brake system must have a valid CIK-FIA homologation.
 ROTAX Rear Tyre Protection System is mandatory to be used. Either 2 or 3 tube version (third tube can be mounted above or below the 2 main tubes). No part shall be added or removed from original content (except safety wire or bolt connection between pos 1 and pos 2 in adjacent picture as well as number plate with support). Only orange or red original ROTAX tyre protection rollers are allowed to be used.

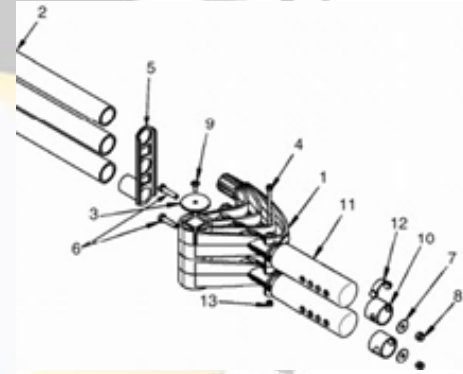

2.2 – BODYWORK

In accordance with ATC UAE and CIK-FIA regulations unless specified otherwise above.

2.3 – TYRES

The permitted tyres for each class are detailed below.
 Strictly no modifications or tyre treatment are allowed (max threshold value 4 ppm).
 The marked direction of rotation must be adhered to at all times.

Dry tyres:

| | | | |
|---------------------------|---------|----------------------|---------------------|
| 125 Micro MAX | MOJO D1 | Front 4.5 x 10.0 - 5 | Rear 4.5 x 10.0 - 5 |
| 125 Mini MAX | MOJO D1 | Front 4.5 x 10.0 - 5 | Rear 7.1 x 11.0 - 5 |
| 125 Junior MAX | MOJO D1 | Front 4.5 x 10.0 - 5 | Rear 7.1 x 11.0 - 5 |
| 125 MAX | MOJO D2 | Front 4.5 x 10.0 - 5 | Rear 7.1 x 11.0 - 5 |
| 125 MAX DD2/Master | MOJO D3 | Front 4.5 x 10.0 - 5 | Rear 7.1 x 11.0 - 5 |

Wet tyres:

All classes N/A

2.4 – DATA ACQUISITION

This system, with or without a memory, may permit only (i) the reading/recording of the engine revs (by induction on the sparkplug HT cable), (ii) two indications of temperature, (iii) the speed of one wheel, (iv) X/Y acceleration, (v) lap times, (vi) position (via GPS), (vii) steering wheel angle and (viii) pedal movement.
 Connection of this system to the original ROTAX battery is allowed.

2.5 – COMPOSITE MATERIALS

Composite materials (carbon fibre, etc.) are banned except for the seat, floor tray and brake disc. Alloys from different metals are not considered composite materials.

2.6 – SAFETY EQUIPMENT

Race suit, helmet, kart boots, gloves and other items of driver protection must comply with Article 3 of the CIK Technical Regulations (see also UAE RMC Sporting Regulations 2015-16).

2.7 – FUEL/OIL

Petrol: unleaded commercial quality from petrol station, 95-98 octane.

Oil: XPS-KartTec 2-stroke (CIK homologation no. ~~112340/02, 112305/01, 112376/01~~ 112340/01 and 112340/02).

2.8 – ADVERTISING ON ENGINES

No sponsor stickers, badges, etc. (except ROTAX, MOJO, XPS, Al Ain Raceway and UAE RMC) are allowed on the engine or any of its accessories unless specifically directed by means of a Bulletin or Supplementary Regulation.

3 – ENGINES

Only engines which have been checked and sealed by Al Ain Raceway (UAE ROTAX Distributor) or one of their official authorised Service Centres are allowed to be used.

By sealing an engine Al Ain Raceway (and their Service Centres) take over the responsibility for the conformity of the engine according to the valid Technical Specification. A brand new engine is always checked according to the Technical Specification before sealing.

The engines must be sealed with specific ROTAX engine seals (black anodised aluminium seal with "ROTAX" logo and 6 digit serial number and bar code - see right picture).

ONLY SEALS WITH BARCODE ARE LEGAL TO BE USED!

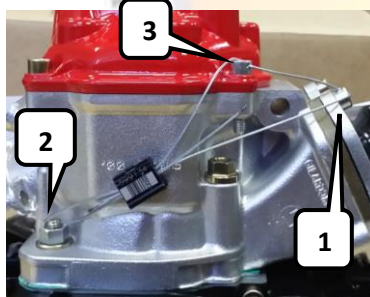

By means of the steel cable the engine must be sealed on one allen screw of the intake flange (1), one stud screw of cylinder (2) and one allen screw of the cylinder head cover (3) - see left picture.

It is mandatory to pass the end of the sealing wire through the seal twice (as in picture).

After sealing the engine the seal thread must be squeezed using ROTAX calliper 276110 (above picture).

Upon every new sealing of an engine Al Ain Raceway (or their Service Centres) is responsible for the following amendments of the Engine Identity Card which belongs to the owner of the engine:

- Serial no. of the engine
- Serial no. of the engine seal
- Stamp and signature of the Company to be able to detect at Scrutineering which authority has checked and sealed the engine.

At Scrutineering the driver must present:

- the engine(s) with undamaged engine seal(s)
- the Engine Identity Card(s) showing the matching engine serial no.(s), the matching engine seal no.(s) and the stamp(s) and signature(s) of the authority that has checked and sealed the engine(s).



The sealing of engines helps to reduce the times for Scrutineering at races as during the race event only the accessories (carburettor, exhaust, radiator.....) need to be checked.

Of course, Scrutineers can request to open and re-check an engine according to the Technical Specification before or after a race or in case of a protest. If an engine seal has been broken (for whatever reason), the engine must be checked completely for compliance according to the Technical Specification. Re-sealing may only then be carried out at the discretion of Al Ain Raceway. If Al Ain Raceway suspects that an engine has been tampered with in any way, that engine will be excluded from competition and will not be resealed under any circumstances.

It is the responsibility of the competitor that all components outside the seal are in line with the Technical Regulations.

4 – MODIFICATIONS, REPAIRS, ADDITIONS:

4.1 – MODIFICATIONS

Neither the engine nor any of its ancillaries may be modified in any way. "Modified" is defined as any change in form, content or function that represents a condition of difference from that originally designed. This is to include the addition and/or omission of parts and/or material from the engine package assembly unless specifically allowed within these rules. The adjustment of elements specifically designed for that purpose shall not be classified as modifications, i.e. carburettor and exhaust valve adjustment screws.

The repair of a thread on the crankcase (max one per engine) or cylinder using a 'heli-coil' or similar is allowed (except threads of the pick-up fixation). Exception: the threads located under the crankcase to fix the crankcase to the engine mount may be repaired as needed.

Only genuine ROTAX components that are specifically designed and supplied for the 125 Micro MAX, 125 Mini MAX, 125 Junior MAX, 125 MAX and 125 MAX DD2 engine are legal, unless otherwise specified. These must originate from Al Ain Raceway.

ANYTHING WHICH IS NOT EXPRESSLY ALLOWED IN THE UAE RMC TECHNICAL REGULATIONS IS FORBIDDEN.

4.2 – INTERNAL ADDITIONS

No additional material may be added except in the case of engine repairs and shall only restore the engine or components to original specifications.

The use of thermal barrier coatings/ceramic coatings on or in the engine and on or in the exhaust system is prohibited.

The use of anti-friction coatings in or on the engine/engine components is prohibited.

4.3 – LEGAL ADDITIONS

Chain guard, engine mount, temperature gauge and tachometer/hour meter, inline fuel filter, catch-cans for liquids with mounting brackets and a supplementary bracket for DENSO ignition coil (only allowed if original position of coil is in conflict with a chassis component), within the limits specified in these regulations.

4.4 – NON-TECH ITEMS

Non-original fasteners, circlips, washers, throttle cable housing, fuel and pulse line (type and size) as well as lengths of coolant hose are allowed unless otherwise specified.

4.5 – MEASUREMENTS

When taking any dimensional reading of the following technical regulations, in the order of accuracy of 0.1 mm (or even more precise), the temperature of the part must be between +10°C and +30°C.

In order to avoid excessive noise and exhaust emissions, revving the engine in the servicing park is not permitted (except in the case of a short function test).

It is the responsibility of the competitor to check his/her equipment (all components outside the engine seal and mentioned below), to ensure that his/her equipment is in line with all technical specifications below!



5 – TECHNICAL SPECIFICATION (WITHIN SEAL) FOR ROTAX KART ENGINES: 125 JUNIOR MAX, 125 MAX, 125 MAX DD2

125 JUNIOR MAX EVO, 125 MAX EVO, 125 MAX DD2 EVO

For engine configurations 125 Micro MAX and 125 Mini MAX, the technical specification of 125 Junior MAX is valid for anything unspecified in the Appendix. Similarly, for engine configurations 125 Micro MAX EVO and 125 Mini MAX EVO, the technical specification of 125 Junior MAX EVO is valid for anything unspecified in the Appendix.

PLEASE NOTE THAT **THREE POSSIBLE OPTIONS** EXIST IN EACH CLASS REGARDING THE COMBINATION OF ELIGIBLE COMPONENTS:

1. ORIGINAL MAX ENGINE WITH ALL ORIGINAL EXISTING MAX COMPONENTS
2. ORIGINAL MAX ENGINE WITH **REGISTERED EVO ACCESSORY KIT UPGRADE**
3. **NEW MAX EVO ENGINE WITH COMPLETE EVO ACCESSORY KIT AS SUPPLIED**

4. For Option 2 (**EVO upgrade kit**), the existing engine must have been presented to Al Ain Raceway to be registered for use with the **complete EVO pack**. Once registered, this engine unit can only be used with the prescribed **EVO accessories**. It is **NOT PERMITTED** to use any of the original MAX components with this engine during race meetings.

Indiscriminate mixing of old and new (**EVO**) accessories is prohibited, unless otherwise specified within these regulations or through an official Bulletin.

5.1 – SQUISH GAP

The squish gap must be measured with a certified slide gauge and by using a 2 mm tin wire. The crankshaft must be turned by hand slowly over TDC (top dead centre) to squeeze the tin wire. The squish gap must be measured on the left and right side in the direction of the piston pin. The average value of the two measurements counts.

Recommended 2mm tin wire (580 130)

| | |
|--|-------------------|
| 125 Junior MAX and 125 Junior MAX EVO | minimum = 1.20 mm |
| 125 MAX and 125 MAX EVO | minimum = 1.00 mm |
| 125 MAX DD2 and 125 MAX DD2 EVO | minimum = 1.30 mm |

5.2 – COMBUSTION CHAMBER INSERT

5.2.1 Cast identification code must be "223 389," "223 389 1," "223 389 2," "223 389 2/1" or "223 389 2/2" (see picture right)

5.2.2 Cast wording "ROTAX" and/or "MADE IN AUSTRIA" must be shown (see picture right)

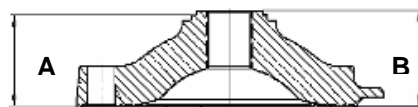

5.2.3 Heights of combustion chamber insert must be 27.55 mm with a tolerance of +0.0/-0.1 mm (A) and 28.80 mm with a tolerance of +/- 0.2 mm (B)

5.2.4 The profile of the combustion chamber insert must be checked with a template (ROTAX part no. 277 390). The crack of light between the template and the profile of the combustion chamber insert must be the same over the whole profile.



5.3 – PISTON WITH RING ASSEMBLY

5.3.1 Original, coated aluminium, cast piston with one piston ring. The piston must show on the inside the cast wording "ELKO" (1) and "MADE IN AUSTRIA" (2).

5.3.2 Machined areas are: top end of piston, outside diameter, groove for the piston ring, bore for the piston pin, inside diameter at bottom end of piston and some pre-existing factory removal (3) of flashing at the cut out of the piston skirt. All other surfaces are not machined and have cast surface.

5.3.3 Original, magnetic, rectangular piston ring.
Ring height: 0.98 +/- 0.02 mm
Piston ring is marked either with "ROTAX 215 547" or "ROTAX 215 548"

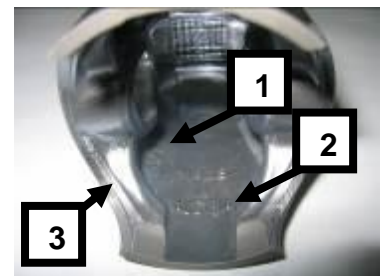

5.4 - PISTON PIN

5.4.1 Piston is made out of magnetic steel.

5.4.2 Dimensions must be according to the drawing.



5.4.3 The minimum weight of the piston pin must not be lower than 32.10g

5.5 - CYLINDER

Light-alloy-cylinder with GILNISIL-plating. Any re-plating of cylinder is not allowed. Maximum bore of cylinder = 54.035mm (measured 10mm above exhaust port) Cylinder must be marked with the "ROTAX" logo (see pictures below).

125 Junior MAX and 125 Junior MAX EVO

Cylinder with one main exhaust port but without exhaust valve.

Cylinder must be marked either with identification code 223 999, 223 998 or 223 994.



125 MAX and 125 MAX EVO

Cylinder with one main exhaust port and exhaust valve.

Cylinder must be marked either with identification code 223 997, 223 996 or 223 993.



125 MAX DD2 and 125 MAX DD2 EVO

Cylinder with one main exhaust port, two side exhaust ports and exhaust valve.

Cylinder must be marked either with identification code 613 930, 613 931 or 613 933.



5.5.1 Height of Cylinder

Measured with a digital caliper min length 200mm

125 Junior MAX / 125 Junior MAX EVO 87mm -0.05/+0.1mm

125 MAX / 125 MAX EVO 87mm -0.05/+0.1mm

125 MAX DD2 / 125 MAX DD2 EVO 86.7mm -0.05/+0.1mm



5.5.2 Cylinder Surfaces

5.5.2.1 All transfer ports and passages have cast finish surface except some removal (done by the manufacturer) of cast burr at the inlet passage and exhaust port and passages. All ports have chamfered edges to prevent ring snagging. Any additional machining is not permitted.

The top edge of exhaust port may show some pre-existing machining from the manufacturer. The sealing flange for the exhaust socket may show signs of machining from the manufacturer (see picture right).



5.5.2.2 All ports have chamfered edges (see picture right). Any additional machining is not permitted.



On cylinders marked 223993, 223994 and 613933 the upper edge of the central boost port may show factory machining (see picture left).



5.5.2.3 The sealing flange for the exhaust socket may show either cast finish or machined surface (see picture right). Machined surface can be either flat or show a circular sealing bump.



5.5.2.4 The top edge of the exhaust port may show either just a cast finish surface (picture below left) or signs of a CNC machining (picture below centre) or signs of CNC machining in combination with signs of manual grinding (picture below right).



The exhaust port may show partial manual grinding done by the manufacturer to eliminate minor casting defects and to eliminate the NIKASIL burr at the end of the NIKASIL plating.

The exhaust ports of cylinders 223993, 223994 and 613933 may show factory machining all around (see picture right).



5.5.3 Exhaust Port Timing

The "exhaust port timing" (distance from the top of the cylinder to the top of the exhaust port) must be checked by means of the template (ROTAX part 277397).

Insert the template into the cylinder so that the template is touching the cylinder wall and the finger of the template is located in the middle of the exhaust port (highest point).

Move the template upwards until the finger is touching the top edge of the exhaust port. Insert a feeler gauge between the top of the cylinder and the template. It MUST NOT be possible to fit the feeler gauge specified below:



125 Junior MAX / 125 Junior MAX EVO

0.90 mm for cylinder 223998/999
1.10mm for cylinder 223994

125 MAX / 125 MAX EVO

0.75 mm for cylinder 223993/996/997

Note: For cylinder 223993 it is also legal if the template does not fit in at all.

125 MAX DD2 / 125 MAX DD2 EVO

0.75 mm for cylinder 613990/931/930

Note: For cylinder 613933 it is also legal if the template does not fit in at all.

5.5.4 Exhaust Valve (125 MAX, 125 MAX DD2, 125 MAX EVO, 125 MAX DD2 EVO)

If the piston is moved to the top of the cylinder until it completely covers the exhaust port, it must be possible to insert the exhaust valve gauge (ROTAX part 277030) until it stops at the surface of the cylinder (a feeler gauge of 0.05 mm must not be possible to fit in)

Modifying the exhaust valve gasket (part 250 231) is illegal.



5.6 – INLET SYSTEM

5.6.1 Inlet manifold is marked with the name "ROTAX" and identification code:

| | |
|-------------------------------------|-----------|
| 125 Junior MAX / 125 Junior MAX EVO | "267 915" |
| 125 MAX / 125 MAX EVO | "267 915" |
| 125 MAX DD2 / 125 MAX DD2 EVO | "267 410" |

5.6.2 Some factory flash removal may be present at the conjunction of the inside contour and the carburettor stop mounting face. This is a manual trimming operation consisting of a small corner break of less than 3 mm in width. No additional grinding or machining is permitted.

5.6.3 The reed valve assembly is equipped with 2 petal stops and 2 reeds, each having 3 petals.

5.6.4 The thickness of the reeds is 0.6 mm +/- 0.10 mm.



5.7 – CRANKSHAFT

5.7.1 Stroke 54.5 mm +/-0.1 mm

5.7.2 Con rod must show forged numbers "213", "365", "367" or "362" on shaft.

5.7.3 Shafts of con rods "213", "365" and "367" are not machined (copper plated). Shaft of con rods "362" is not copper-plated and blank (grey). Grinding or polishing of shaft of con rod is not permitted.



5.8 – CRANKSHAFT MAIN BEARINGS

Crankshaft main bearing 6206 from FAG only is allowed Must be marked with code **579165BA** or **Z-579165.11.KL**



5.9 – BALANCE SHAFT

(125 JUNIOR MAX, 125 MAX, 125 JUNIOR MAX EVO, 125 MAX EVO)

5.9.1 Balance shaft and balance gears must be installed.

5.9.2 Configurations of part no. 237949 (equal with 237948) only is legal.

5.9.3 Surface (1) is not machined and must show cast surface.

5.9.4 Measurement from centre of balance shaft to outer diameter of fly weight of balance shaft at defined length must not be lower than specified.

5.9.5 The minimum weight of the dry balance shaft must not be lower than 255g for balance shaft 237949 (equal with 237948).

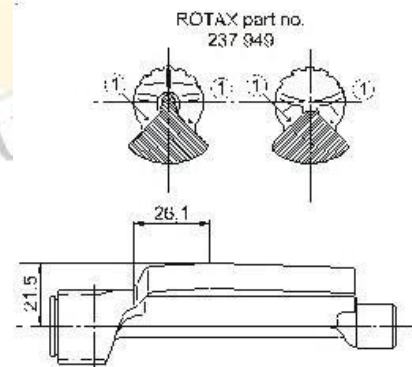

5.10 – 2-SPEED GEARBOX (125 MAX DD2 AND 125 MAX DD2 EVO)

5.10.1 Primary shaft with 19 teeth for 1st gear and 24 teeth for 2nd gear.

5.10.2 Idle gear for 1st gear must have 81 teeth.

5.10.3 Idle gear for 2nd gear must have 77 teeth.

5.11 – CRANKCASE

As supplied by the manufacturer. No grinding/polishing is permitted in the two main transfer passages as well as in the crank area.

Uncoated as well as black coated crankcases are legal to be used.

6 – TECHNICAL SPECIFICATION (OUTSIDE SEAL) FOR ROTAX KART ENGINES: 125 JUNIOR MAX, 125 MAX, 125 MAX DD2

125 JUNIOR MAX EVO, 125 MAX EVO, 125 MAX DD2 EVO

It is the responsibility of the competitor to check all components outside the engine seal to ensure that they are in line with the technical specifications below.

For engine configurations 125 Micro MAX and 125 Mini MAX, the technical specification of 125 Junior MAX is valid for anything unspecified in the Appendix. Similarly, for engine configurations 125 Micro MAX EVO and 125 Mini MAX EVO, the technical specification of 125 Junior MAX EVO is valid for anything unspecified in the Appendix.

6.1 – BALANCE DRIVE

125 JUNIOR MAX, 125 MAX, 125 JUNIOR MAX EVO, 125 MAX EVO

Balance gears must be installed and aligned according to the instruction in the repair manual.

Steel balance gears (picture right) are only legal to be used with new type centrifugal clutch – see also 6.2.

Mixing of steel balance gears of different width (6.0mm and 9.0mm) is strictly forbidden.

Old version "plastic" balance gears (picture right) can only be used with old type centrifugal clutch and only on original MAX engines (NOT a legal option for 125 Junior MAX EVO and 125 MAX EVO).

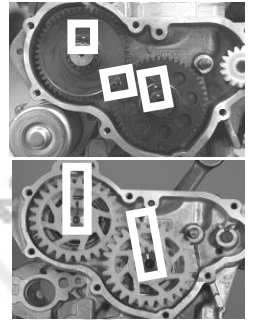

125 MAX DD2, 125 MAX DD2 EVO

Balance drive gear must be fitted on crank shaft.

Balance gear must be fitted on primary shaft and must be aligned with the balance drive gear according to the instruction in the repair manual.

Version 1: Fly weight of balance gear must show cast surface.

Version 2: Fly weight of balance gear can show machined surface.

Dimension A (widest part of balance weight) must be either 53 mm +/- 0.5mm or 57 mm +/- 0.5mm

The minimum weight of a dry balance gear including bearing must not be less than 240g.

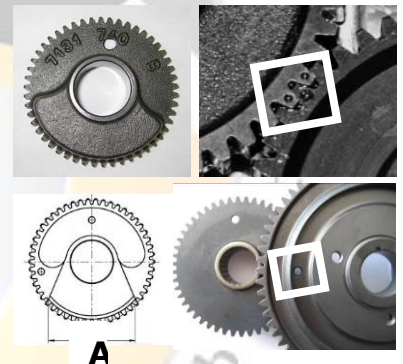

6.2 – CENTRIFUGAL CLUTCH

125 JUNIOR MAX, 125 MAX, 125 JUNIOR MAX EVO, 125 MAX EVO

Dry centrifugal clutch with engagement speed at maximum 4,000 rpm, i.e. the kart (without driver) must start to move before a maximum engine speed of 4,000 rpm.

Both versions of clutch (item 3 on diagram, with/without holes) are legal to be used.

O-Ring (item 10) must be fitted and must ensure appropriate sealing between the clutch drum and the needle/plain bearing (item 9).

Signs of emission of grease from the needle/plain bearing may not exceed the adjacent picture.

The contact area between the clutch and clutch drum must be completely dry at all times – no lubrication allowed under any circumstances!

Old version clutch (springs/shoes) is legal but NOT permitted on EVO engines.

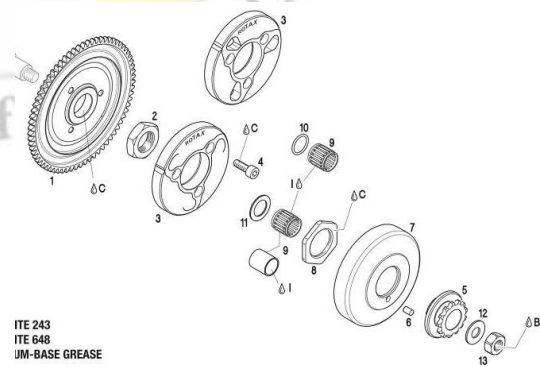

ITE 243
ITE 648
UM-BASE GREASE



125 MAX DD2, 125 MAX DD2 EVO

Centrifugal clutch with engagement speed at maximum 4,000 rpm, i.e. the kart (without driver) must start to move before a maximum engine speed of 4,000 rpm.

Both versions of clutch (item 6 on diagram, with/without holes) are legal to be used.

O-Ring (item 11) must be fitted.

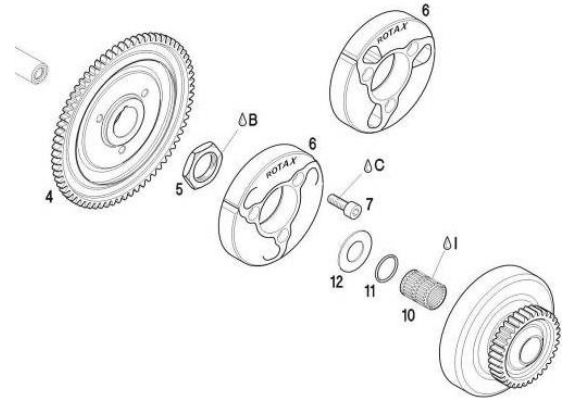

6.2.1 Height of Clutch (pic right)

| | |
|------------------------------------|--------------------|
| 125 Junior MAX, 125 Junior MAX EVO | minimum = 11.45 mm |
| 125 MAX, 125 MAX EVO | minimum = 11.45 mm |
| 125 MAX DD2, 125 MAX DD2 EVO | minimum = 14.45 mm |



6.2.2 Thickness of Clutch Shoe (pic below left)

| | |
|------------------------------------|--------------------|
| 125 Junior MAX, 125 Junior MAX EVO | minimum = 24.10 mm |
| 125 MAX, 125 MAX EVO | minimum = 24.10 mm |
| 125 MAX DD2, 125 MAX DD2 EVO | minimum = 24.10 mm |

Measurement must be done at the 3 open ends of the clutch shoes, 5-10mm from the machined groove. All clutch shoes must be completely closed (no gap).



6.2.3 Outer Diameter of Clutch Drum

| | |
|------------------------------------|---------------------------------------|
| 125 Junior MAX, 125 Junior MAX EVO | minimum = 89.50 mm (pic above centre) |
| 125 MAX, 125 MAX EVO | minimum = 89.50 mm (pic above centre) |
| 125 MAX DD2, 125 MAX DD2 EVO | minimum = 89.50 mm (pic above right) |

Diameter must be measured with a sliding calliper beside the radius from the shoulder (not at the open end of the clutch drum).

6.2.4 Inner Diameter of Clutch Drum

| | |
|------------------------------------|--|
| 125 Junior MAX, 125 Junior MAX EVO | maximum = 84.90 mm (pic below left) |
| 125 MAX, 125 MAX EVO | maximum = 84.90 mm (pic below left) |
| 125 MAX DD2, 125 MAX DD2 EVO | maximum = 84.90 mm (pic below 2 nd from left) |

The inner diameter must be measured with a sliding calliper. The measurement must be taken in the middle of the clutch drum (in the contact area between clutch and drum).



6.2.5 Height of Clutch Drum

| | |
|------------------------------------|---|
| 125 Junior MAX, 125 Junior MAX EVO | minimum = 33.90 mm (pic 2 nd from right) |
| 125 MAX, 125 MAX EVO | minimum = 33.90 mm (pic 2 nd from right) |
| 125 MAX DD2, 125 MAX DD2 EVO | minimum = 39.50 mm (pic extreme right) |

6.3 – PRIMARY DRIVE (125 MAX DD2, 125 MAX DD2 EVO)

Original primary drive gears of following gear ratio options must be used. Only mentioned pairs are legal to be used:

| Drive gear | Driven gear |
|------------|-------------|
| 33 | 64 |
| 34 | 63 |
| 35 | 62 |
| 36 | 61 |
| 37 | 60 |

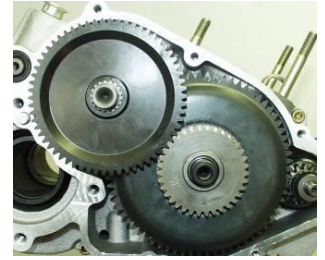

A specific primary gear ratio may be determined for each race event by a "Supplementary Regulation" or "Bulletin".

6.4 – GEAR SHIFTING (125 MAX DD2, 125 MAX DD2 EVO)

The 2-speed gearbox must be operated from the steering wheel via two Bowden cables.

Two versions of original paddle shift systems are legal to be used:

Version 1 - Plastic shift paddles (pic right)

Cutting of the original shift paddles (item 23) or the adding of pads to the shift paddles to adjust the paddles to specific steering wheels is permitted.

Original plastic steering wheel hub (item 27, part no 660 640) must be used.

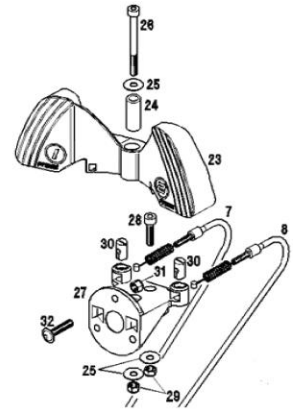

Version 2 – Aluminium shift paddles (pic right)

Cutting of the original aluminium shift paddles (item 31) or the adding of non-original parts is not allowed.

Mounting the shift paddles on the bottom or top side of the whip (item 25) is an allowed adjustment. Optional parts (items 36-38) can be mounted on the shift paddle in any position.

Bending the aluminium shift paddles to align them to the steering wheel is an allowed adjustment.

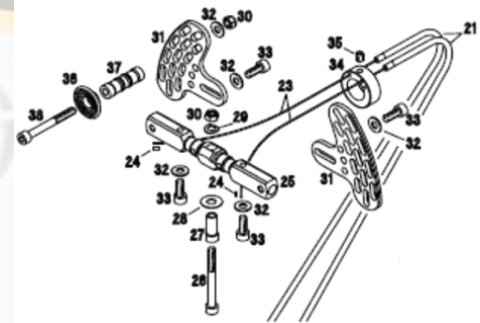

6.5 – EXHAUST VALVE

As supplied by the manufacturer with no modification allowed.

Length of exhaust valve is 36.5 mm +0.20 mm/-0.30 mm.

Width of collar is 4.8 mm +/-0.3 mm

Only the green coloured exhaust valve bellow is legal to be used (ROTAX part number 260723)

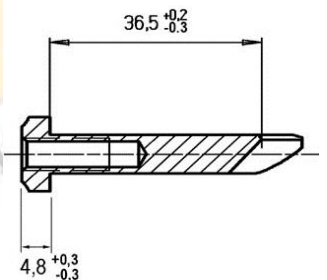

Two versions of original exhaust valve systems (pneumatic/electronic timed) are legal to be used according to the engine configuration (original or EVO) as specified below.

VERSION 1: PNEUMATIC TIMED EXHAUST VALVE 125 MAX, 125 MAX DD2 ONLY

System must be used as supplied with all components fitted.

125 MAX - compression spring, length 42.5mm (item 14, part number 239942/3) must be fitted.

125 MAX DD2 - compression spring, length 48.5mm (item 14, part number 239940) must be fitted.

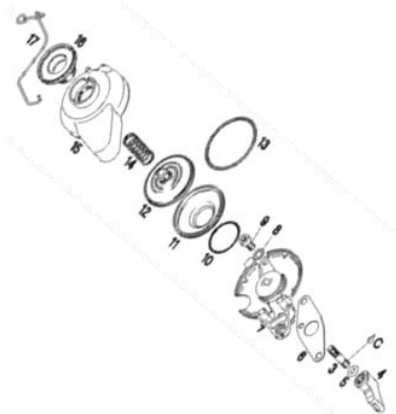

VERSION 2: ELECTRONIC TIMED EXHAUST VALVE 125 MAX EVO, 125 MAX DD2 EVO ONLY

System must be used as supplied with all components fitted with the exception of the impulse nozzle (item 22) which is optional.

If used, the impulse nozzle must be fitted inside the pressure hose (item 23).

The direction of the impulse nozzle is free.

Compression spring (item 13, part number 239952) length 48.5mm must be fitted.

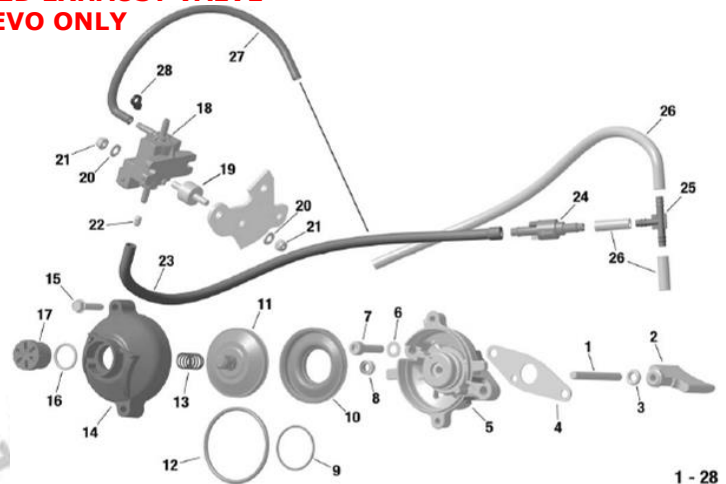

6.6 – IGNITION SYSTEM

Digital battery ignition with variable ignition timing as supplied by the manufacturer. No adjustments necessary or possible.

Spark plug – only the following are legal to be used:
DENSO Iridium **IW 27** or **IW 29** or **IW 31** or **IW 34**.

Spark plug cap must be marked with "NGK TB05EMA".

The marking of the pick-up must show the following numbers in the first line 029600-0710 (see pic right).

A steel ball (diameter 3-5 mm) placed on the circular surface of the sensor must stay in the centre of the circular surface.



Two versions of original ignition systems (Denso and Dellorto) are legal to be used according to the engine configuration (original or **EVO**) as specified below.

Race officials may request at any time that the competitor replaces the ignition coil (Denso ignition system) or electronic box (Dellorto ignition system) with another unit provided by the race administration.

VERSION 1: DENSO IGNITION SYSTEM

The casting of the ignition coil must show "129000-" and "DENSO" in the casting.

125 JUNIOR MAX, 125 MAX ONLY

Ignition coil must show 3 pins at the terminal.

Connector housing of ignition coil must have either black or green colour. Ignition coils 265572 & 265578 are permitted. 265571 (assembly) is not permitted.

The minimum length of the high tension cable is 210 mm from outlet at ignition coil to outlet of spark plug connector (= the visible length of wire).

The ignition coil must be fixed by means of 2 original silent blocks to the gearbox cover. In case of chassis component interference with the original mounting location of the coil, a supplementary extension bracket (rigid, solid metal, of minimum dimensions and attached to the original fixation holes of the gearbox cover) is permitted for the mounting of the coil.

The fitting of a 2nd original mass cable (item 8, part 264910) is an allowed option.

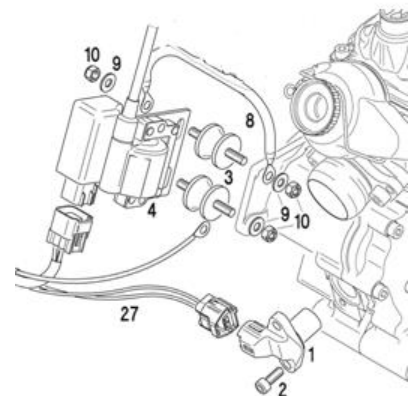

125 MAX DD2 ONLY

Ignition coil must show 4 or 6 pins at the terminal.

Connector housing of ignition coil must have either white or grey colour.

The minimum length of the high tension cable is 210 mm from outlet at ignition coil to outlet of spark plug connector (= the visible length of wire).

The fitting of a 2nd original mass cable (item 8, part 264910) is an allowed option.

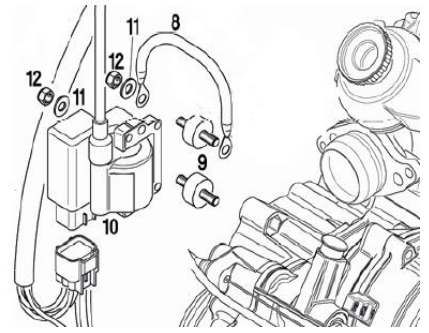

The ignition coil must be fixed by means of 2 original silent blocks to the left side of the crankcase. A supplementary extension bracket (rigid, solid metal, of minimum dimensions and attached to the original fixation holes of the crankcase) is permitted in case of chassis component interference with the original coil mounting location.

VERSION 2: DELLORTO IGNITION SYSTEM

125 JUNIOR MAX EVO, 125 MAX EVO, 125 MAX DD2 EVO ONLY

The ignition coil is the same for all **EVO** engine variants an electronic box (ECU) is separate and specific for each engine type.

Both the ignition coil and electronic box must be fitted by means of the corresponding brackets and components according to the adjacent illustrations:

Pic upper right – 125 Junior MAX EVO / 125 MAX EVO [also 125 Micro MAX EVO / 125 Mini MAX EVO]

Pic lower right – 125 MAX DD2 EVO

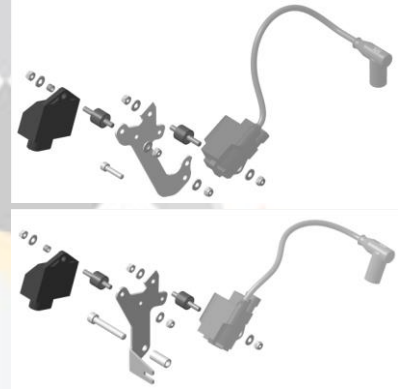

It is mandatory to fit the ignition coil by means of a Rotax original rubber buffer to the bracket, as shown.

The visual appearance of the ignition coil must be identical to the adjacent pictures.

Ignition coil must show 2 pins at the terminal.

The ignition coil is labeled with two stickers, "BRP 666820" and "NIG 0105". The ignition coil is still legal to be used if one or both stickers is/are missing.

The minimum length of the high tension cable of the ignition coil is 210 mm from outlet of ignition coil to outlet of spark plug connector (visible length of cable).



The ground cable of the cable harness must be connected to the engine at the location of the rear left Allen screw of the cylinder head cover.

The inclusion of one or maximum two original gaskets (part 431500, thickness 0.8mm) between the pick-up and the crankcase is an allowed option for **EVO**-spec engines (in addition to the original rubber sealing ring).

Fitting position of the additional gasket(s):

Recommended: Crankcase / rubber sealing ring / gasket(s) / pick-up

Optional: Crankcase / gasket(s) / rubber sealing ring / pick-up

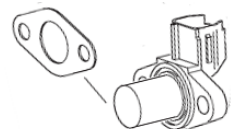

Each electronic control unit (ECU) is labeled with a sticker but is still legal if the sticker is unreadable or is missing.

125 Junior MAX:

"666812, 125 Junior MAX EVO"

125 MAX (also 125 Micro MAX, 125 Mini MAX):

"666814, 125 MAX EVO"

125 MAX DD2:

"666816, 125 MAX DD2 EVO"

The ECU must be checked using ECU tester (Rotax part no. 276230) according to following procedure:

- Disconnect engine cable harness from ECU
- Connect ECU tester cable harness to ECU
- Connect energy cable of ECU tester cable harness with the charging connector of engine cable harness.
- Start the test by pressing the button "✓" on the ECU tester.

After approx. 1 second the type of ECU ① that is actually tested will be indicated [in the second line of the display].

After approx. 15 seconds the result ② of the test will be indicated [in the first line of the display].

The test must be performed using the software version **1V22** of the ECU tester (indicated at every start of an ECU test).

The ECU tester has to indicate following results:

125 Junior MAX category

- ① Jnr. MAX EVO
- ② !! Test OK !!

125 MAX category (also 125 Micro MAX and 125 Mini MAX)

- ① MAX EVO
- ② !! Test OK !!

125 MAX DD2 category

- ① MAX DD2 EVO
- ② !! Test OK !!



6.7 – BATTERY AND BATTERY FIXATION

Original batteries with the following specification only are legal to be used:

YUASA YT7B-BS (with and without Rotax branding)

ROTAX RX7-12B or **ROTAX** RX7-12L (lithium iron phosphate type)

Battery must be fitted with the original battery clamp and battery cover and must be fixed to the chassis with both clamps (at least 4 screws).

Battery clamp must be mounted on the left side of the seat.

Two versions are legal to be used according to the engine configuration (original or **EVO**) as specified below. Battery must be mounted with all components as shown in the illustration either like version 1 (below left) or like version 2 (below right).

VERSION 1

- 125 JUNIOR MAX**
- 125 MAX**
- 125 MAX DD2**

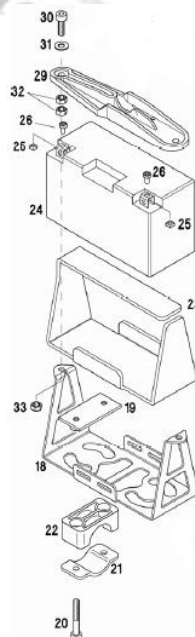

VERSION 2

- 125 JUNIOR MAX EVO**
- 125 MAX EVO**
- 125 MAX DD2 EVO**

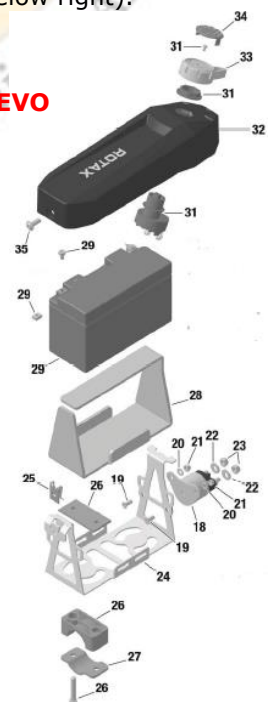

6.8 – INTAKE SILENCER 125 JUNIOR MAX, 125 MAX, 125 JUNIOR MAX EVO, 125 MAX EVO

Intake silencer with integrated, washable air filter must be used with all parts as shown in illustration and must be mounted on the support bracket with two screws (in dry and wet race condition).

Intake silencer tube (pos 2) and carburettor socket (pos 6) are only legal if marked with "ROTAX".

The intake silencer case bottom is marked on the inside with ROTAX part no. 225015.

The intake silencer case top is marked on the inside with ROTAX part no. 225025.

Two versions of original air filter (pos 4) are legal:

Version 1 – single layer (black)

Version 2 – double layer (green/black marked "TwinAir". Air filter must be installed as shown in illustration between the two holders (pos 3) and must cover the complete area of the intake silencer bottom (pos 1).

It is not allowed to attach anything to the air box to protect the air inlet from water spray even in wet conditions.

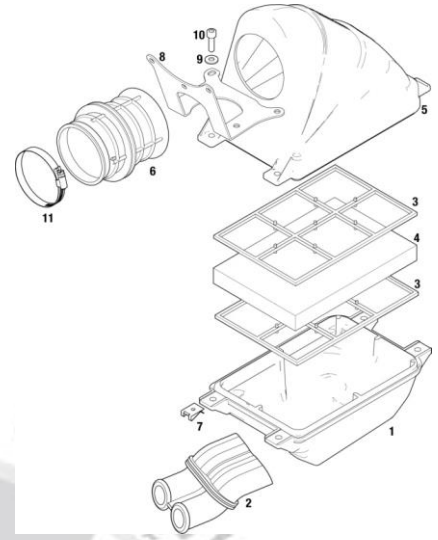

125 MAX DD2, 125 MAX DD2 EVO

Intake silencer with integrated, washable air filter as shown in illustration.

The intake silencer case (pos 1) is marked on the inside with ROTAX part no. 225012 (4 clips) or 225013 (5 clips).

The intake silencer cover (pos 2) is marked on the inside with ROTAX part no. 225022 (4 clips) or 225023 (5 clips).

Two versions of air filters (pos 3) are legal:

Version 1 – integrated steel frame

Version 2 – separate plastic frame (pos 4)

The air filter must be assembled between the intake silencer case and the intake silencer cover so that the whole area of the intake silencer case is covered.

Use of the O-ring (pos 6) on the intake silencer tube is mandatory.

Sealing the top of the airbox using adhesive tape is an allowed modification.

It is not allowed to attach anything to the air box to protect the air inlet from water spray even in wet conditions.

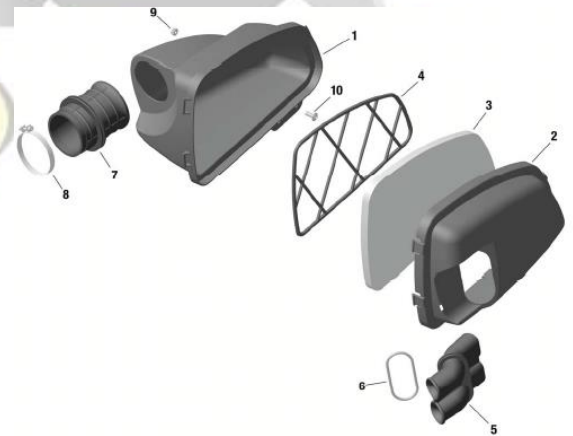

6.9 – CARBURETTOR

Two versions are legal to be used according to the engine configuration (original or EVO). The following regulations apply to both versions (specific regulations for each version are detailed thereafter).

Dellorto carburettor housing must show the cast wording "VHSB 34".

The complete inlet bore of the carburettor must show cast surface.

Optional carburettor plug screw (ROTAX part no. 261030) is legal to be used.

The two vent fittings must be connected with the original air vent hose minimum length 155mm (ROTAX part no. 260260). The location of the opening must be placed at the rear side of the carburettor.

Settings of the carburettor adjustment screws (idle and idle air) are free.

The position of the jet needle is free.

All jets must be correctly seated and securely fitted (tight).

The height of the two arms of the float lever must be within the slot of the carburettor gauge (ROTAX part no. 277400) by their normal weight, measured at the carburettor housing in the reverse upright position without the gasket (see picture right).



Needle valve assembly is stamped "150". For 125 MAX DD2 "200" is also a legal option. Needle of needle valve marked with diamond symbol "INC" only (see picture right)



Start jet is stamped with the digits "60"

Optional items ROTAX part no. 240184 (allen screw, 2pcs.) and ROTAX part no. 261552 (main jet cup, 1pc.) are legal to be used. These parts optionally replace the parts 262020 and 261550 in the case of sealing a carburettor.

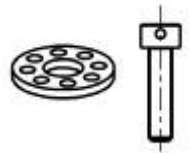

Restrictions on the size of main jet may be determined for each race event by a Supplementary Regulation or Bulletin.

SPECIFIC REGULATION FOR 125 JUNIOR MAX, 125 MAX, 125 MAX DD2 (VHSB QS)

DELL'ORTO carburettor with "QS" stamped on the carburettor housing. The carburettor year identification must be 05 onwards.

The carburettor slide must show size "40" in casting and the bottom end of the slide must show a cast surface.

Jet needle stamped must be stamped with "K98".

Only the following combination of floats and idle jets is legal:

125 JUNIOR MAX, 125 MAX

Floats are marked with "gr 3.6"

Idle jet is stamped "60"

Idle emulsion tube is stamped "60"

Carb insert is stamped 8.5 (see picture right)

Main jets smaller than 158 are not permitted

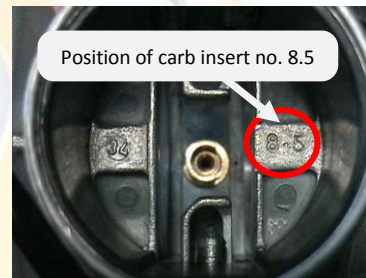

125 MAX DD2

Floats are marked with "gr 5.2"

Idle jet is stamped "30"

Idle emulsion tube is stamped "30"

Carb insert is stamped 8.5 (see picture right)

Main jets smaller than 180 are not permitted

Needle jet must be stamped with "FN 266" and have the following dimensions:

Total length 54.00 +/- 0.3 mm (pic below left)

Length of bottom section 11.50 +/- 0.2 mm (pic below centre)

Top bore diameter 2.60 +/- 0.15 mm (pic right)



4x4 cross holes diameter:

Using jet gauge set (ROTAX part no. 281920) it must not be possible for plug gauge 0.90 mm to enter any one of the 16 holes (pic right).



Idle jet 60: using jet gauge set (ROTAX part no. 281920) it must not be possible for plug gauge 0.65 mm to enter the bore of idle jet 60 (*pic right*).



Idle emulsion tube 60: using jet gauge set (ROTAX part no. 281920) it must not be possible for plug gauge 0.65 mm to enter the bore (*pic far left*).



Using jet gauge set (ROTAX part no. 281920) it must not be possible for plug gauge 0.65 mm to enter any one of the 4 cross bores (*pic near left*).

Idle jet 30 (125 MAX DD2 only): It must not be possible for plug gauge 0.36 mm to enter the bore of idle jet 30 (*pic right*).



Idle emulsion tube 30 (125 MAX DD2 only): it must not be possible for plug gauge 0.36 mm to enter the bore of the idle jet emulsion tube 30 (picture far left).



Using jet gauge set (ROTAX part no. 281920) it must not be possible for plug gauge 0.65 mm to enter any one of the 4 cross bores (picture near left).

Carburettor insert 8.5 must meet the following criteria:



Angular bore: using jet gauge set (ROTAX part no. 281920) it must not be possible for plug gauge 0.60 mm to fit (*pic left*).

Vertical bore: using jet gauge set (ROTAX part no. 281920) it must not be possible for plug gauge 0.90 mm to fit (*pic right*).



Atomiser must meet the following criteria:

Using venturi tool set (ROTAX part no. 676034) the control pin $\varnothing 3.6\text{mm}$ must enter the atomiser (*pic right*).

Total length 23.75 +/- 0.45 mm (*pic below far left*)

Length of cylindrical part 15.75 +/- 0.25 mm (*pic below middle left*)

Dimension of cutaway 6.00 +/- 0.15 mm (*pic below middle right*)

Diameter of cross bore 4.05 +/- 0.15 mm (*pic below far right*)



Note: Use venturi tool set (ROTAX part no. 676034) to remove atomiser from carb body.

SPECIFIC REGULATION FOR 125 JUNIOR MAX EVO, 125 MAX EVO, 125 MAX DD2 EVO (VHSB 34 XS)

DELL'ORTO carburettor with "XS" stamped on the carburettor housing.

The carburettor slide must show size "45" in casting.

Jet needle must be stamped with "K57".

Only the following combination of floats/jets is legal:

125 JUNIOR MAX EVO, 125 MAX EVO, 125 MAX DD2 EVO

Floats are marked with "4.0 gr"

Idle jet is stamped "60"

Idle emulsion tube is stamped "45"

Carb insert is stamped 12.5 (see picture right)



Needle jet must be stamped with "DP267" and have the following dimensions:

Total length 51.00 +/- 0.3 mm (pic below left)

Length of bottom section 33.00 +/- 0.2 mm (pic below right)



6.10 – FUEL PUMP, FUEL FILTER

FUEL PUMP

MIKUNI diaphragm pump (pic right) must be used mounted on the support bracket as shown in the illustration.



125 JUNIOR MAX, 125 MAX, 125 Junior MAX EVO, 125 MAX EVO

Fuel pump must be mounted on the bottom side of the support bracket for the intake silencer (left illustration).

125 MAX DD2, 125 MAX DD2 EVO

Fuel pump should be mounted on the support bracket, marked 651055, attached to the clutch cover (right illustration).



Mounting the fuel pump with the two original rubber buffers to the chassis is an allowed option. In this case the fuel pump must be mounted below the inlet center line of the carburettor.

FUEL FILTER

The original fuel filter versions only (pictures right) are allowed to be fitted between the fuel tank and the fuel pump.

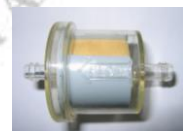

No additional parts except the fuel line, fuel pump as well as the original fuel filter are legal to be mounted between the fuel tank and the carburettor.



6.11 – RADIATOR

The removal of the thermostat from the cylinder head cover is an acceptable configuration.

Radiator must be mounted with all components as shown in the respective illustrations (version 1, version 2 or version 3).

To apply tape (neutral tape without advertising only) around the radiator is an allowed modification to air flow through the radiator.

Tape may not be removed from the radiator during operation on the track.

Any other non-original device to control the air flow through the radiator is prohibited.

125 JUNIOR MAX, 125 MAX, 125 JUNIOR MAX EVO, 125 MAX EVO

The radiator must be mounted on the right side of the engine.
Three different versions are legal to be used according to engine configuration:

Version 1
125 JUNIOR MAX, 125 MAX

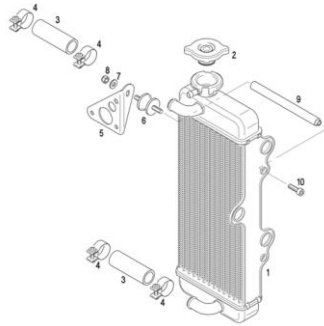

Cooling area:
Height = 290 mm
Width = 133 mm
Thickness = 32 mm

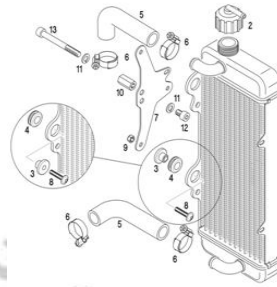

Cooling area:
Height = 290 mm
Width = 133 mm
Thickness = 32 mm

Version 3
125 JUNIOR MAX, 125 MAX
125 JUNIOR MAX EVO, 125 MAX EVO

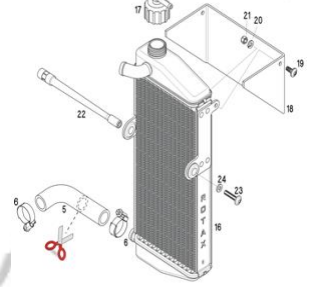

Cooling area:
Height = 290 mm
Width = 138 mm
Thickness = 34 mm

For version 2 the support plate (pos 7) enables two different mounting positions (height) of the radiator. Both mounting positions are legal to be used.

For version 3 the radiator must be stamped on the side with the wording "ROTAX". Removal of the original plastic flap (version 3) is an acceptable configuration.

125 MAX DD2, 125 MAX DD2 EVO

The radiator must be mounted on the left side of the driver's seat.

The highest point of the radiator with cap may not be higher than 400 mm above the main tube of the kart chassis.

"ROTAX" stamped on top/side of radiator.

Two versions are legal to be used according to the engine configuration (original or EVO).

Version 1
125 MAX DD2

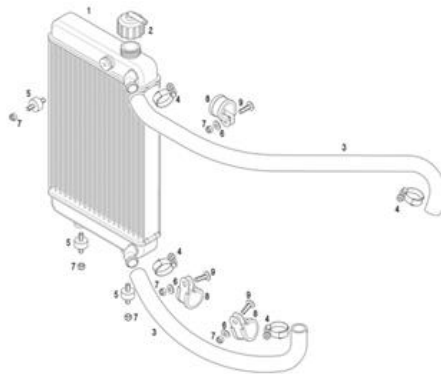

Cooling area:
Height = 284 mm
Width = 202 mm
Thickness = 32 mm

Version 2
125 MAX DD2
125 MAX DD2 EVO

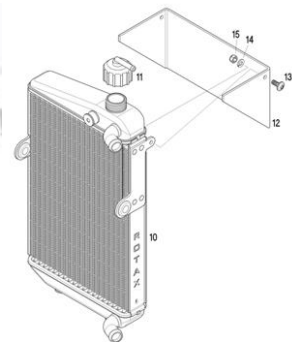

Cooling area:
Height = 290 mm
Width = 196 mm
Thickness = 34 mm

Removal of the original plastic flap (version 2) is an acceptable configuration.

6.12 - COOLANT

Plain water without any additives must be used.

6.13 – EXHAUST SYSTEM

Different versions are legal to be used according to the engine configuration (original or **EVO**). The following regulations apply to all versions (specific regulations for each version are detailed thereafter).

Original exhaust system as supplied by Rotax is mandatory to be used. Welding of the exhaust is not permitted other than to repair the support brackets in case of failure.

Allowed modifications on original exhaust systems are:

- Replacement of the original rivets of the silencer end cap by 4 mm metric screws and corresponding locking nuts.
- Replacement of the isolating mat (only one original isolating mat may be fitted) inside the silencer and the silencer end cap with perforated tube within the limits described below.
- For measuring the exhaust gas temperature it is allowed to weld a socket on top of the exhaust, 50-80 mm from the ball joint.
- Addition of a steel isolating mat (ROTAX part no. 297983) of square dimension 165 + 10 mm is legal to be assembled underneath the standard isolation mat. Clamp (1) must be fitted at a distance of 18 +/- 2 mm, measured from the end of the tube (*pic right*). Clamp (2) must be fitted at the end area of the steel isolation mat (*pic right*). 10-12mm is a specification for assembly purpose only. Both clamps (1 and 2) are mandatory and must be fitted and tightened.

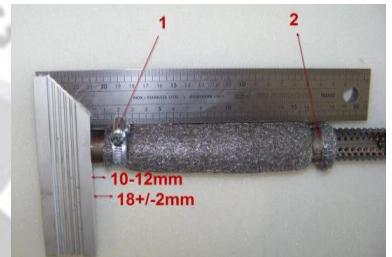

The use of a maximum 4 pieces of original ROTAX exhaust springs to fix the exhaust to the cylinder is allowed (no safety wire allowed in exhaust flange area).

125 JUNIOR MAX, 125 MAX, 125 JUNIOR MAX EVO, 125 MAX EVO

Three different versions are legal to be used according to engine configuration:

Version 1
125 JUNIOR MAX, 125 MAX

Version 2
125 JUNIOR MAX, 125 MAX

Version 3
125 JUNIOR MAX EVO, 125 MAX EVO

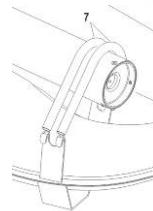
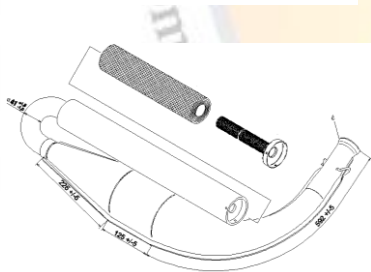

Tuned pipe and silencer are one piece. Silencer is welded to the 180° elbow and the tuned pipe.

Tuned pipe and silencer are one piece. Silencer is welded to the 180° elbow. Two springs fix the silencer to the tuned pipe.

Tuned pipe with 180° elbow and silencer are two separate pieces. Silencer is fixed with 2 springs to the 180° elbow and 2 springs to the tuned pipe.

For Version 1 & 2 (**125 JUNIOR MAX, 125 MAX** only), the following measurements are valid:
 Maximum diameter of silencer end cap hole is 21.00 mm
 Length of inlet cone is 592 mm +/- 5 mm (measured on outside from beginning of exhaust pipe until beginning of cylindrical part)
 Length of cylindrical part of exhaust pipe is 125 mm +/- 5 mm
 Length of end cone: 225 mm, +/- 5 mm
 Outside diameter of 180° bent tube is 41mm +1.5 mm/-1.0 mm (measured at beginning and end of bend).

For Version 3 (**125 JUNIOR MAX EVO, 125 MAX EVO** only), the silencer can be turned so that the 90° elbow outlet of the silencer shows either downwards or backwards. Silencer end cap with 90° elbow is mandatory to be used.

To drill an extra hole in the exhaust retaining bracket (part number 651070 MAX) for attachment of a second exhaust spring is a legal modification.

125 MAX DD2, 125 MAX DD2 EVO

Three different versions are legal to be used according to engine configuration:

Version 1
125 MAX DD2

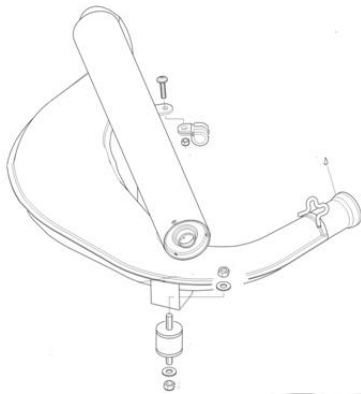

Tuned pipe and silencer are one piece. Silencer is welded to the 180° elbow and the tuned pipe.

Version 2
125 MAX DD2

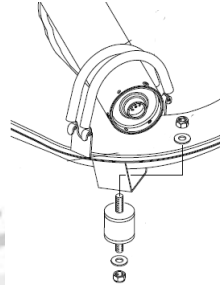

Tuned pipe and silencer are one piece. Silencer is welded to the 180° elbow. 2 springs fix the silencer to the tuned pipe.

Version 3
125 MAX DD2 EVO



Tuned pipe with 180° elbow and silencer are two separate pieces. Silencer is fixed with 2 springs to the 180° elbow and 2 springs to the tuned pipe.

For Version 1 & 2 (125 MAX DD2 only), the following measurement is valid:
Diameter of silencer end cap hole is 19.60 mm +/- 0.2 mm

For Version 3 (125 MAX DD2 EVO only), the silencer can be turned so that the 90° elbow outlet of the silencer shows either downwards or backwards.

Silencer end cap with 90° elbow is mandatory to be used for Version 3.

For Version 3, to drill an extra hole in the exhaust retaining bracket (part number 651075 DD2) for attachment of a second exhaust spring is a legal modification.

EXHAUST SOCKET

Two versions of exhaust socket are legal to be used according to engine configuration:

Version 1
125 JUNIOR MAX, 125 MAX,
125 MAX DD2



Version 1 (without gasket ring – pic left) must be used for all original 125 JUNIOR MAX, 125 MAX and 125 MAX DD2.

Version 2 (with gasket ring – pic right) must be used for all original 125 JUNIOR MAX EVO, 125 MAX EVO and 125 MAX DD2 EVO.

For Version 2 the measurement (C) must be at least 15.5 mm (pic right).

Version 2
125 JUNIOR MAX EVO, 125 MAX EVO,
125 MAX DD2 EVO

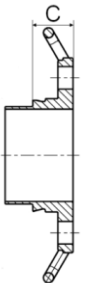

6.14 – ADDITIONAL SEAT SUPPORT

On the engine side a maximum of one additional seat support is allowed to be used.

The support must be fastened to the engine using the threaded hole designed for this purpose (pic right). The seat strut may be installed on either side of the threaded bolt hole.



UAE ROTAX MAX CHALLENGE 2015-16 TECHNICAL REGULATIONS

APPENDIX FOR 125 MINI MAX AND 125 MICRO MAX VERSION 23.09.15

A1 – TECHNICAL SPECIFICATION (WITHIN SEAL) FOR ROTAX KART ENGINE 125 MINI MAX, 125 MICRO MAX, 125 MINI MAX EVO, 125 MICRO MAX EVO

Please note that for engine configuration 125 Micro MAX and 125 Mini MAX, the technical specification of 125 Junior MAX is valid for anything unspecified below.

For engine configurations 125 Micro MAX EVO and 125 Mini MAX EVO, the technical specification of 125 Junior MAX EVO is valid for anything unspecified in the Appendix.

A1.1 SQUISH GAP

The squish gap must be measured with a certified slide gauge and by using a 3 mm tin wire for 125 Mini MAX, 125 Micro MAX, 125 Mini MAX EVO, 125 Micro MAX EVO.

The crankshaft must be turned by hand slowly over TDC (top dead centre) to squeeze the tin wire. The squish gap must be measured on the left and right side in the direction of the piston pin. The average value of the two measurements counts.

Recommended 3mm tin wire (580 132)

| | |
|-------------------------------------|-------------------|
| 125 Mini MAX and 125 Mini MAX EVO | minimum = 2.40 mm |
| 125 Micro MAX and 125 Micro MAX EVO | minimum = 2.40 mm |

To achieve this defined squish gap, a spacer (ROTAX part number 626 420) with a thickness of 1.25mm must be used along with the different required base gaskets.

Please note that the authorised sealing authority may impose at their sole discretion a non-negotiable minimum squish gap value which is greater than the above in order to reduce the risk of technical non-conformity due to carbon build-up on the piston.

A2 – TECHNICAL SPECIFICATION (OUTSIDE ENGINE SEAL) FOR ROTAX KART ENGINE 125 MINI MAX AND 125 MINI MAX EVO

For engine configuration 125 Mini MAX, the technical specification of 125 Junior MAX is valid for anything unspecified below. For engine configuration 125 Mini MAX EVO, the technical specification of 125 Junior MAX EVO is valid for anything unspecified below.

It is the responsibility of the competitor to check all components outside the engine seal to ensure that they are in line with the technical specifications below.

A2.1 EXHAUST SOCKET – 125 MINI MAX, 125 MINI MAX EVO

Two versions of exhaust socket are legal to be used according to engine configuration:

Version 1 (ROTAX part number 273 973) can only be used for original 125 MINI MAX.

Version 2 (with gasket ring) must be used for 125 MINI MAX EVO and is also legal for original 125 MINI MAX.

For both versions the maximum inner diameter (A) is 20.10 mm.

Diameter (A) must apply for a length (B) of at least 12 mm.

For Version 2 the measurement (C) must be at least 18.5 mm.

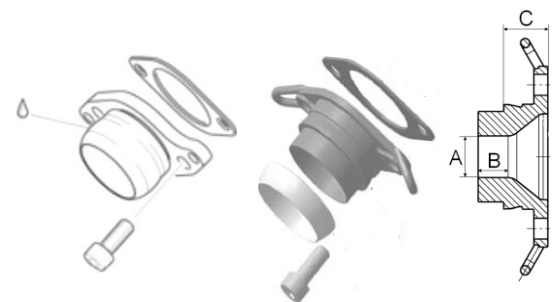

A2.2 IGNITION SYSTEM - 125 MINI MAX EVO ONLY

As indicated in Article 6.6, **125 MINI MAX EVO** utilises the ECU specified for 125 MAX EVO – Rotax part number 666 814.

The ECU tester must indicate following results:

125 MINI MAX EVO category

- ① MAX EVO
- ② !! Test OK !!

A3 – TECHNICAL SPECIFICATION (OUTSIDE ENGINE SEAL) FOR ROTAX KART ENGINE 125 MICRO MAX AND 125 MICRO MAX EVO

For engine configuration 125 Micro MAX, the technical specification of 125 Junior MAX is valid for anything unspecified below. For engine configuration **125 Micro MAX EVO**, the technical specification of **125 Junior MAX EVO** is valid for anything unspecified below. It is the responsibility of the competitor to check all components outside the engine seal to ensure that they are in line with the technical specifications below.

A3.1 CARBURETTOR – 125 MICRO MAX, 125 MICRO MAX EVO

A3.1.1 The spacer (*pos 1 far right*, ROTAX part number 251730) must be fitted in the carburettor to limit the opening of the throttle.

A3.1.2 The length of the spacer must be 38.0 mm \pm 0.2mm.

A3.1.3 The position of the cap of the carburettor must be fixed by means of the fixation plate (*pos 1 in adjacent picture*, ROTAX part number 251790).



A3.1.4 The cap of the carburettor must be screwed completely onto the carburettor (tight).

A3.1.5 Only 1 rubber gasket is allowed to be used in the carburettor cap.

A3.1.6 The tolerance gauge (ROTAX part no. 277400) must **not** be able to turn around (opening limit of carburettor slide)!

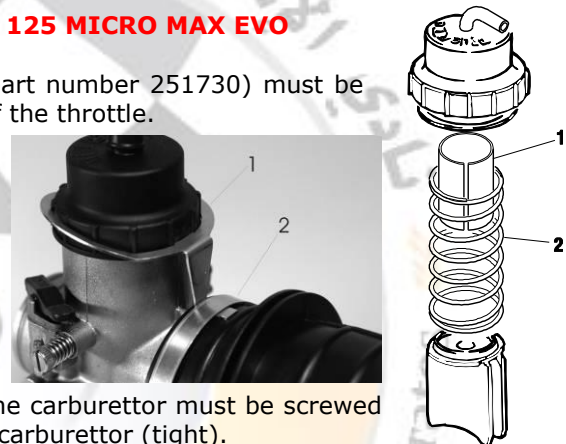

A3.2 EXHAUST SOCKET – 125 MICRO MAX, 125 MICRO MAX EVO

Only exhaust sockets with gasket ring are legal to be used (see *pic right*).

The maximum inner diameter (A) is 18.20 mm.

Diameter (A) must apply for a length (B) of at least 12 mm.

The measurement (C) must be at least 18.5 mm.

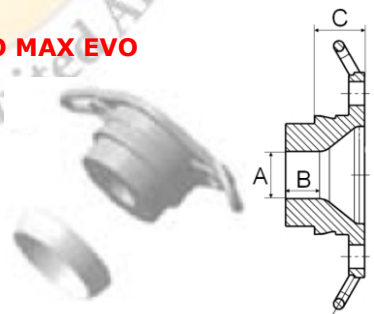

A3.3 IGNITION SYSTEM - 125 MICRO MAX EVO ONLY

As indicated in Article 6.6, **125 MICRO MAX EVO** utilises the ECU specified for 125 MAX EVO – Rotax part number 666 814.

The ECU tester must indicate following results:

125 MICRO MAX EVO category

- ① MAX EVO
- ② !! Test OK !!

A3.4 RADIATOR – 125 MICRO MAX, 125 MICRO MAX EVO

A specific Micro MAX radiator (ROTAX part number 295924 or 295923) must be used. Two different versions are legal are legal to be used according to engine configuration:

Radiator must be mounted with all components as per the illustrations (right).

Cooling area:
Height = 280-300 mm
Width = 58-62 mm

Thickness of radiator = 30-34 mm

Removal of the original plastic flap (Version 2) is an acceptable configuration.

Version 1
125 MICRO MAX

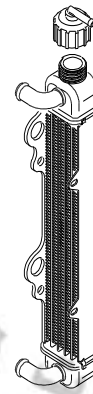

Version 2
125 MICRO MAX
125 MICRO MAX EVO

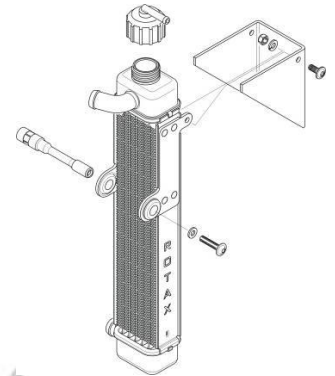

A3.5 EXHAUST SYSTEM – 125 MICRO MAX, 125 MICRO MAX EVO

A specific Micro MAX exhaust system must be used for the 125 Micro MAX and 125 Micro MAX EVO engines. It should be installed according to the guidelines provided by ROTAX.

A minimum of 2 attachment springs from the exhaust pipe to the exhaust socket is mandatory (Rotax part no. 938795 or 938798).

No exhaust leakage is allowed (no signs of oil).

The exhaust flange and socket shape must be concentric. The exhaust must be mounted so that it is centred on the exhaust socket with even spacing all around. No modification, damage or distortion of the exhaust pipe (and exhaust socket) is permitted.

The exhaust screws or rivets on the return end plate should be tightly fastened.

The exhaust cover outlet must be installed as supplied by ROTAX in the downward pointing position.

The exhaust must be installed firmly using either one rigid pipe mount or 2 separate rigid brackets via 2 silent blocks (Rotax part number 660920 – one per support lug). The deflection of the 2 silent blocks is the only pipe movement allowed. The pipe must be mounted in a neutral position (ideally horizontal) with no stress on the 2 silent blocks.

The exhaust must be fitted securely by means of both support lugs which are provided on the underside of the exhaust system for vibration damped suspension of the exhaust.

In addition to the standard isolation mat a special steel mat (ROTAX part no. 297983) of square dimension 165 + 10 mm is mandatory to be assembled underneath the standard isolation mat (picture right).

Clamp (1) must be fitted at a distance of 18 +/- 2 mm, measured from the end of the tube.

Clamp (2) must be fitted at the end area of the steel isolation mat. Both clamps are mandatory.

10-12mm is a specification for assembly purpose only.

'Cover with elbow' (part number 273098) must be used for both 125 Micro MAX and 125 Micro MAX EVO (see pic right).

The inner diameter of the elbow outlet at the silencer end cover must have a minimum measurement of 21.00 mm.

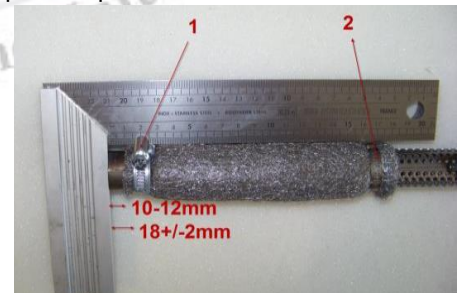

Part number 273098
125 MICRO MAX
125 MICRO MAX EVO

